

RC4391

Inverting and Step-Down Switching Regulator

Features

- Versatile —
Inverting function (+ to -)
Step-down function
Adjustable output voltage
Regulates supply changes
- Micropower —
Low quiescent current — 170 μ A
Wide supply range — 4V to 30V
- High performance —
High switch current — 375 mA
High efficiency — 70% typically
- Low battery detection capability
- 8-lead mini-DIP or S.O. package

Description

Raytheon's RC4391 is a monolithic switch mode power supply controller for micropower circuits. The RC4391 integrates all the active functions needed for low power switching supplies, including oscillator, switch, reference and logic, into a small package. Also, the quiescent supply current drawn by the RC4391 is extremely low; this combination of low supply current, function, and small package make it adaptable to a variety of miniature power supply applications.

The RC4391 complements another Raytheon switching regulator IC, the RC4190. The RC4190 is dedicated to step-up ($V_{OUT} > V_{IN}$) applications, while the RC4391 was designed for inverting ($V_{OUT} = -V_{IN}$) and step-down ($V_{OUT} < V_{IN}$) applications. Between the two devices the ability to create all three basic switching regulator configurations is assured. Refer to the RC4190 data sheet for information on step-up applications.

The functions provided are:

- Squarewave oscillator (adjustable externally)
- Bandgap voltage reference
- High current PNP switch transistor
- Feedback comparator
- Logic for gating the comparator
- Circuitry for detecting a discharged battery condition (in battery powered systems)

Few external components are required to build a complete DC-to-DC converter:

- Inductor
- Low value capacitor to set the oscillator frequency
- Electrolytic filter capacitor
- Steering diode
- Two resistors

Block Diagram

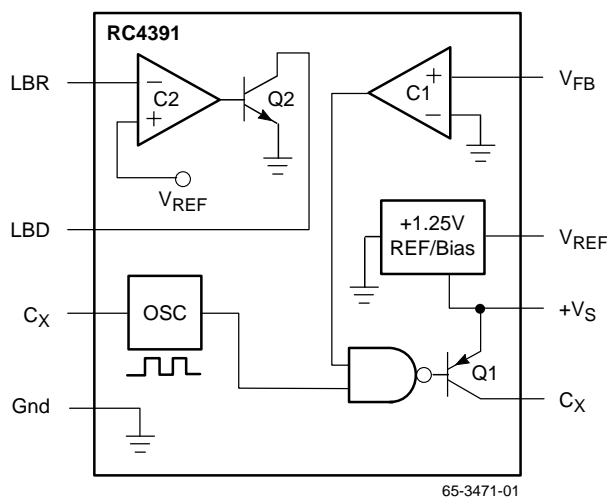

Pin Assignments

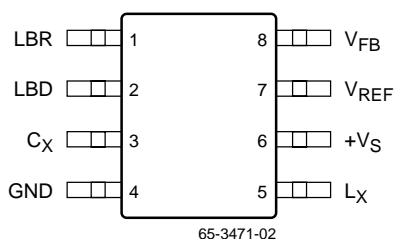

Pin Descriptions

Pin Number	Pin Function Description
1	Low Battery Resistor (LBR)
2	Low Battery Detector (LBD)
3	Timing Capacitor (CX)
4	Ground
5	External Inductor (LX)
6	+Supply Voltage (+VS)
7	+1.25V Reference Voltage (VREF)
8	Feedback Voltage (VFB)

Absolute Maximum Ratings

Parameter	Conditions	Min	Typ	Max	Unit
Internal Power Dissipation				500	mW
Supply Voltage ¹	(Pin 6 to Pin 4 or Pin 6 to Pin 5)			+30	V
Operating Temperature	RC4391	0		70	°C
	RV4391	-25		85	°C
	RM4391	-55		125	°C
Storage Temperature		-65		150	°C
Junction Temperature	PDIP, SOIC			125	°C
	CerDIP			175	°C
Switch Current (IMAX)	Peak			375	mA
PD TA <50°C	PDIP			468	mW
	CerDIP			833	mW
	SOIC			300	mW
Lead Soldering Temperature	(10 seconds)			300	°C

Note:

1. The maximum allowable supply voltage (+VS) in inverting applications will be reduced by the value of the negative output voltage, unless an external power transistor is used in place of Q1.

Thermal Characteristics

	8-Lead Plastic DIP	8-Lead Ceramic DIP	Small Outline SO-8
Therm. Res θ_{JC}	—	45°C/W	—
Therm. Res. θ_{JA}	160°C/W	150°C/W	240°C/W
For TA >50°C Derate at	6.25 mW/°C	8.33 mW/°C	4.17 mW/°C

Electrical Characteristics

($V_S = +6.0V$, over the full operating temperature range unless otherwise noted)

Symbol	Parameters	Condition	Min	Typ	Max	Units
+VS	Supply Voltage	(Note 1)	4.0		30	V
ISY	Supply Current	$V_S = +25V$		300	500	μA
VREF	Reference Voltage		1.13	1.25	1.36	V
VOUT	Output Voltage	$V_{OUT\ nom} = -5.0V$	-5.5	-5.0	-4.5	V
		$V_{OUT\ nom} = -15V$	-16.5	-15.0	-13.5	
LI1	Line Regulation	$V_{OUT\ nom} = -5.0V$, $C_X = 150pF$ $V_S = +5.8V$ to $+15V$		2.0	4.0	%VOUT
		$V_{OUT\ nom} = -15V$, $C_X = 150pF$ $V_S = +5.8V$ to $+15$		1.5	3.0	
LO1	Load Regulation	$V_{OUT\ nom} = -5.0V$, $C_X = 350pF$, $V_S = +4.5V$, $P_{LOAD} = 0mW$ to $75mW$		0.2	0.5	%VOUT
		$V_{OUT\ nom} = -15V$, $C_X = 350pF$, $V_S = +4.5V$, $P_{LOAD} = 0mW$ to $75mW$		0.2	0.3	
ICO	Switch Leakage Current	Pin 5 = $-20V$		0.1	30	μA

Note:

- The maximum allowable supply voltage (+VS) in inverting applications will be reduced by the value of the negative output voltage, unless an external power transistor is used.

Electrical Characteristics

($V_S = +6.0V$, $T_A = +25^\circ C$ unless otherwise noted)

Symbol	Parameters	Condition	Min	Typ	Max	Units
ISY	Supply Voltage	$V_S = +4.0V$, No External Loads		170	250	μA
		$V_S = +25V$ No External Loads		300	500	
VOUT	Output Voltage	$V_{OUT\ nom} = -5.0V$	-5.35	-5.0	-4.65	V
		$V_{OUT\ nom} = -15V$	-15.85	-15.0	-14.15	
LI1	Line Regulation	$V_{OUT\ nom} = -5.0V$ $C_X = 150pF$, $V_S = +5.8V$ to $+15V$		1.5	3.0	%VOUT
		$V_{OUT\ nom} = -15V$, $C_X = 150pF$ $V_S = +5.8V$ to $+15V$		1.0	2.0	
LO1	Load Regulation	$V_{OUT\ nom} = -5.0V$, $C_X = 350pF$, $V_S = +4.5V$, $P_{LOAD} = 0mW$ to $75mW$		0.2	0.4	%VOUT
		$V_{OUT\ nom} = -15V$, $C_X = 350pF$, $V_S = +4.5V$, $P_{LOAD} = 0mW$ to $75mW$		0.07	0.14	
VREF	Reference Voltage		1.18	1.25	1.32	V
ISW	Switch Current	Pin 5 = 5.5V	75	100		mA
ICO	Switch Leakage Current	Pin 5 = -24V		0.01	5.0	μA
ICX	Cap. Charging Current	Pin 3 = 0V	6.0	10	14	μA
ILBDL	LBD Leakage Current	Pin 1 = 1.5V, Pin 2 = 6.0V		0.01	5.0	μA
ILBD0	LBD On Current	Pin 1 = 1.1V, Pin 2 = 0.4V	210	600		μA
ILBRB	LBR Bias Current	Pin 1 = 1.5V		0.7		μA

Typical Performance Characteristics

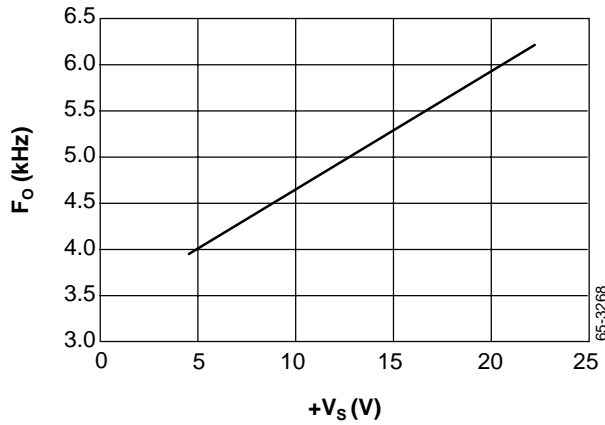

Figure 1. Oscillator Frequency vs. Supply Voltage

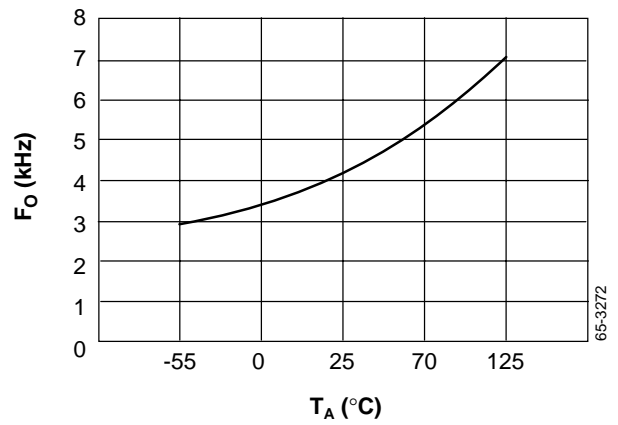

Figure 2. Oscillator Frequency vs. Temperature

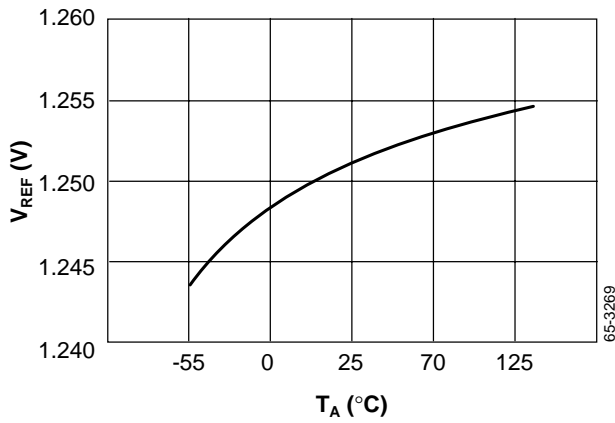

Figure 3. Reference Voltage vs. Temperature

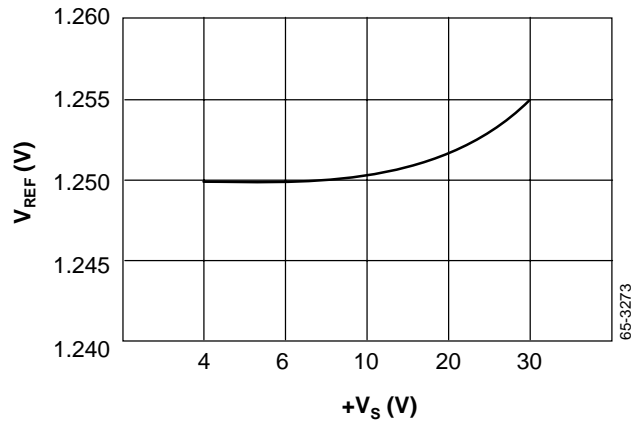

Figure 4. Reference Voltage vs. Supply Voltage

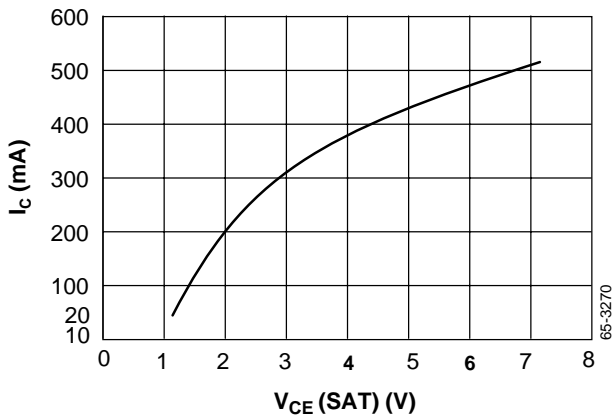

Figure 5. Collector Current vs. Q1 Saturation Voltage

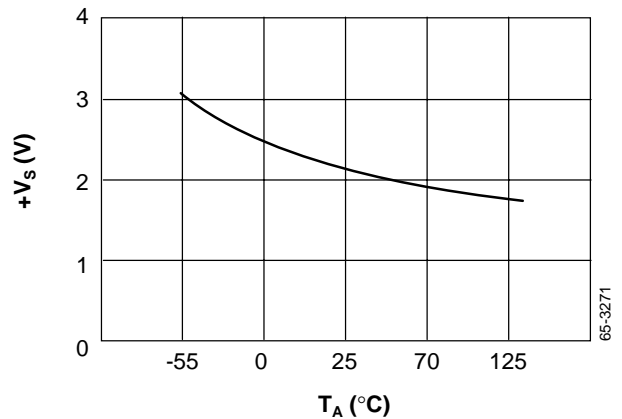
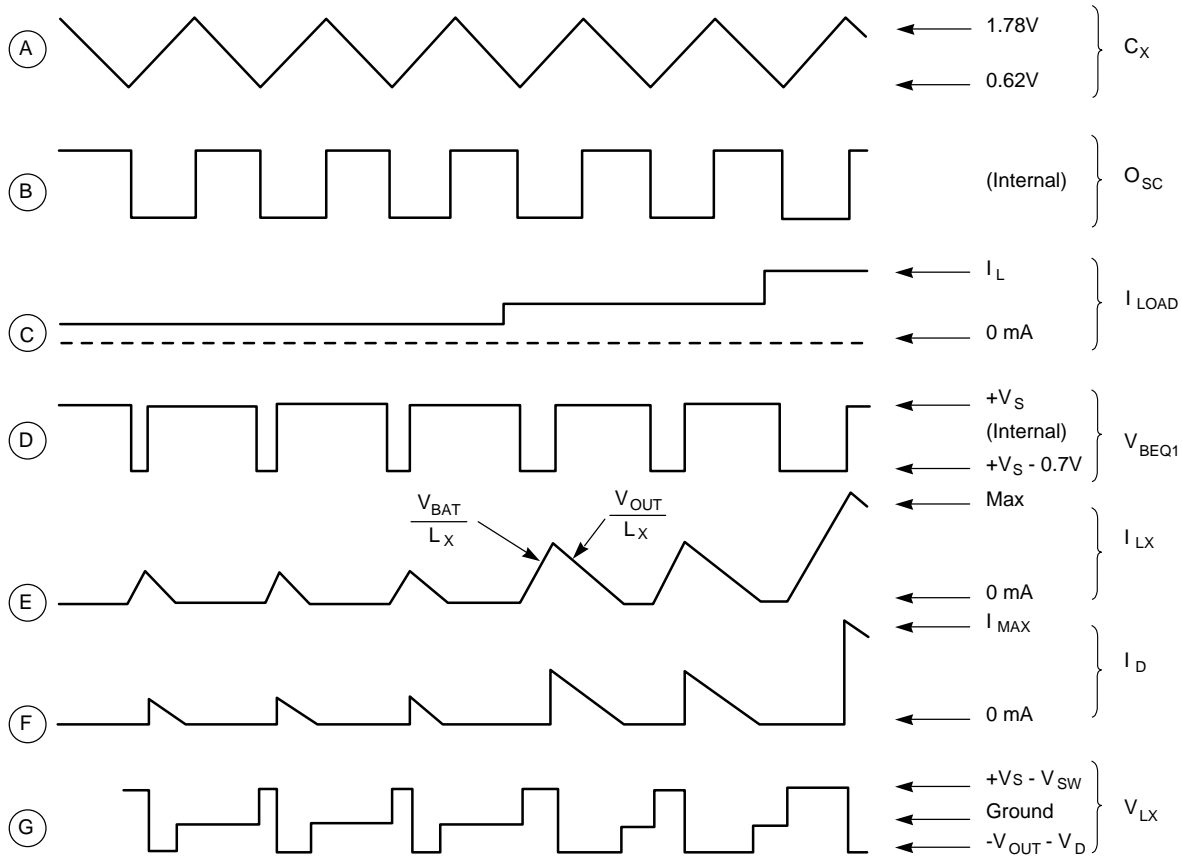

Figure 6. Minimum Supply Voltage vs. Temperature



65-2472

Figure 9. Inverting Regulator Waveforms

This feedback system will vary the duration of the on time in response to changes in load current or battery voltage (see Figure 9). If the load current increases (waveform C), then the transistor will remain on (waveform D) for a longer portion of the oscillator cycle, (waveform B) to build up to a higher peak value. The duty cycle of the switch transistor varies in response to changes in load and line.

Step-Down Regulator

The step-down circuit function is similar to inversion; it uses the same components (switch, inductor, diode, filter capacitor), and charges and discharges the inductor by closing and opening the switch. The great difference is that the inductor is in series with the load; therefore, both the charging current and the discharge current flow into the load. In the inverting circuit only the discharge current flows into the load. Refer to Figure 10.

When the switch S is closed, current flows from the battery, through the inductor, and through the load resistor to ground. After the switch is opened, stored energy in the inductor causes current to keep flowing through the load, the circuit being completed by the catch diode D. Since current flows to the load during charge and discharge, the average load cur-

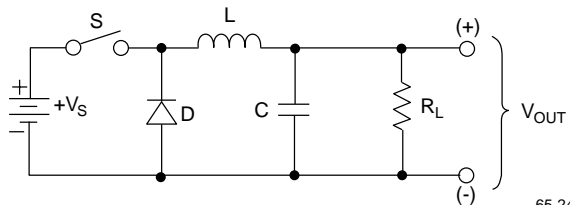

65-2473

Figure 10. Simple Step-Down Regulator

rent will be greater than in an inverting circuit. The significance of that is that for equal load currents the step-down circuit will require less peak inductor current than an inverting circuit. Therefore, the inductor will not require as large of a core, and the switch transistor will not be stressed as heavily for equal load currents.

Figure 11 depicts a complete schematic for a step-down circuit using the RC4391. Observe that the ground lead of the 4391 is **not** connected to circuit ground; instead, it is tied to the output voltage. It is by this rearrangement that the feedback system, which senses voltages more negative than the ground lead, can be used to regulate a non-negative output voltage.

When power is first applied, the output filter capacitor is discharged so the ground lead potential starts at 0V. The reference voltage is forced to +1.25V above the ground lead and pulls the feedback input (pin 8) more positive than the ground lead. This positive voltage forces the control network to begin pulsing the switch transistor. As the switching action pumps up the output voltage, the ground lead rises with the output until the voltage on the ground lead is equal to the feedback voltage. At that point, the control network reduces the time on time of the switch to maintain a constant output.

This control network will vary the on time of the switch in response to changes in load current or battery voltage (see Figure 12). If the load current increases (waveform C), then the transistor will remain on (waveform D) for a longer portion of the oscillator cycle, (waveform B), thus allowing the

inductor current (waveform E) to build up to a higher peak value. The duty cycle of the switch transistor varies in response to changes in load and line.

Design Equations

The inductor value and timing capacitor (C_X) value must be carefully tailored to the input voltage, input voltage range, output voltage, and load current requirements of the application. The key to the problem is to select the correct inductor value for a given oscillator frequency, such that the inductor current rises to a high enough peak value (I_{MAX}) to meet the average load current drain. The selection of this inductor value must take into account the variation of oscillator frequency from unit to unit and the drift of frequency over temperature. Use ±30% as a maximum variation of oscillator frequency.

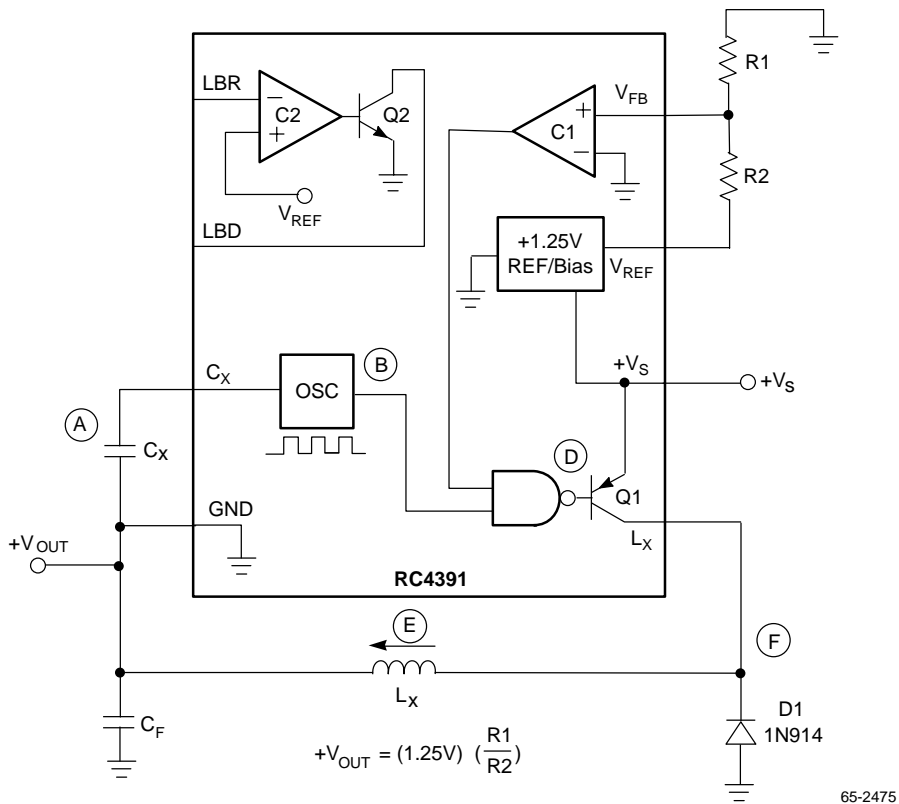

Important Note: This circuit must have a minimum load ≥ 1 mA always connected.

Figure 11. Step-Down Regulator – Standard Circuit

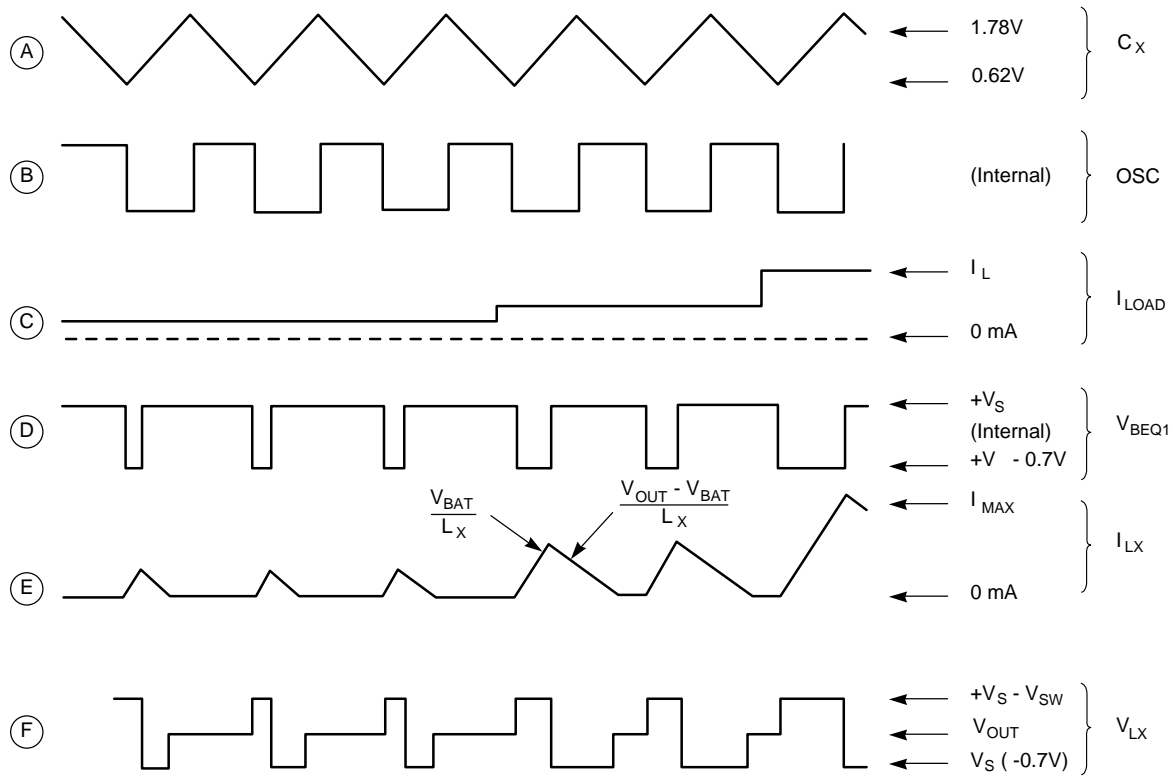

65-2474

Figure 12. Step-Down Regulator Waveforms

The oscillator creates a squarewave using a method similar to the 555 timer IC, with a current steering flip-flop controlled by two voltage sensing comparators. The oscillator frequency is set by the timing capacitor (C_X) according to the following equation.

$$F_O(\text{Hz}) = \frac{4.1 \times 10^{-6}}{C_X(\text{pF})}$$

The squarewave output of the oscillator is internal and cannot be directly measured, but is equal in frequency to the triangle waveform measurable at pin 3. The switch transistor is normally on when the triangle waveform is ramping up and off when ramping down. Capacitor selection depends on the application; higher operating frequencies will reduce the output voltage ripple and will allow the use of an inductor with a physically smaller inductor core, but excessively high frequencies will reduce load driving capability and efficiency.

Inverting Design Procedure

1. Select an operating frequency and timing capacitor value as shown above (frequencies from 10kHz to 50kHz are typical).

2. Find the maximum on time T_{ON} (add $3\mu\text{S}$ for the turn off base recombination delay of Q1):

$$T_{ON} = \frac{1}{2F_O} + 3\mu\text{S}$$

3. Calculate the peak inductor current I_{MAX} (if this value is greater than 375mA then an external power transistor must be used in place of Q1):

$$I_{MAX} = \frac{(V_{OUT} + V_D)2I_L}{(F_O)(T_{ON})(V_S - V_{SW})}$$

Where:

V_S = Supply Voltage
 V_{SW} = Saturation Voltage of Q1 (typically 0.5V)
 V_D = Diode Forward Voltage (typically 0.7V)
 I_L = DC Load Current

4. Find an inductance value for L_X :

$$L_X(\text{Henries}) = \left(\frac{V_S - V_{SW}}{I_{MAX}} \right) (T_{ON})$$

The inductor chosen must exhibit this value of inductance and have a current rating equal to I_{MAX} .

Step-Down Design Procedure

1. Select an operating frequency.
2. Determine the maximum on time T_{ON} as in the inverting design procedure.
3. Calculate I_{MAX} :

$$I_{MAX} = \frac{2I_L}{(F_O)(T_{ON}) \left[\frac{(V_S - V_{OUT})}{(V_{OUT} - V_D)} + 1 \right]}$$

4. Calculate L_X :

$$L_X(\text{Henries}) = \left(\frac{V_S - V_{SW}}{I_{MAX}} \right) (T_{ON})$$

Alternate Design Procedure

The design equations above will not work for certain input/output voltage ratios, and for these circuits another method of defining component values must be used. If the slope of the current discharge waveform is much less than the slope of the current charging waveform, then the inductor current will become continuous (never discharging completely), and the equations will become extremely complex. So, if the voltage applied across the inductor during the charge time is greater than during the discharge time, use the design procedure below. For example, a step-down circuit with 20V input and 5V output will have approximately 15V across the inductor when charging, and approximately 5V when discharging. So in this example the inductor current will be continuous and the alternate procedure will be necessary. The alternate procedure may also be used for discontinuous circuits.

1. Select an operating frequency based on efficiency and component size requirements (a value between 10kHz and 50kHz is typical).
2. Build the circuit and apply the worst case conditions to it, i.e., the lowest battery voltage and the highest load current at the desired output voltage.
3. Adjust the inductor value down until the desired output voltage is achieved, then decrease its value by 30% to cover manufacturing tolerances.
4. Check the output voltage with an oscilloscope for ripple, at high supply voltages, at voltages as high as are expected. Also check for efficiency by monitoring supply and output voltages and currents:

$$\left(\text{eff} = \frac{(V_{OUT})(I_{OUT})}{(+V_S)(I_{SY}) \times 100} \right)$$

5. If the efficiency is poor, go back to Step 1 and start over. If the ripple is excessive, then increase the output filter capacitor value or start over.

Compensation

When large values ($> 50 \text{ k}\Omega$) are used for the voltage setting resistors (R1 and R2 of Figure 8) stray capacitance at the V_{FB} input can add lag to the feedback response, destabilizing the regulator, increasing low frequency ripple, and lowering efficiency. This can often be avoided by minimizing the stray capacitance at the V_{FB} node. It can also be remedied by adding a lead compensation capacitor of 100 pF to 10 nF. In inverting applications, the capacitor connects between $-V_{OUT}$ and V_{FB} ; for step-down circuits it connects between ground and V_{FB} . Most applications do not require this capacitor.

Inductors

Efficiency and load regulation will improve if a quality high Q inductor is used. A ferrite pot core is recommended; the wind-yourself type with an air gap adjustable by washers or spacers is very useful for bread-boarding prototypes. Care must be taken to choose a core with enough permeability to handle the magnetic flux produced at I_{MAX} . If the core saturates, then efficiency and output current capability are severely degraded and excessive current will flow through the switch transistor. A pot core inductor design section is provided later in this datasheet.

An isolated AC current probe for an oscilloscope (example: Tektronix P6042) is an excellent tool for saturation problems; with it the inductor current can be monitored for non-linearity at the peaks (a sign of saturation).

Low Battery Detector

An open collector signal transistor Q2 with comparator C2 provides the designer with a method of signaling a display or computer whenever the battery voltage falls below a programmed level (see Figure 13). This level is determined by the +1.25V reference level and by the selection of two external resistors according to the equation:

$$V_{TH} = V_{REF} \left(\frac{R4}{R5} + 1 \right)$$

When the battery drops below this threshold Q2 will turn on and sink typically 600µA. The low battery detection circuit can also be used for other less conventional applications such as the voltage dependent oscillator circuit of Figure 18.

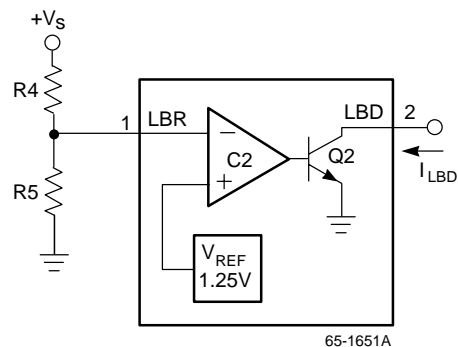

Figure 13. Low Battery Detector

Device Shutdown

The entire device may be shut down to an extremely low current non-operating condition by disconnecting the ground (pin 4). This can be easily done by putting an NPN transistor in series with ground pin and switching it with an external signal. This switch will not affect the efficiency of operation, but will add to and increase the reference voltage by an amount equal to the saturation voltage of the transistor used. A mechanical switch can also be used in series between circuit ground and pin 4, without introducing any reference offset.

Power Transistor Interfaces

The most important consideration in selecting an external power transistor is the saturation voltage at $I_C = I_{MAX}$. The lower the saturation voltage is, the better the efficiency will be. Also, a higher beta transistor requires less base drive and therefore less power will be.

Also, a higher beta transistor requires less base drive and therefore less power will be consumed in driving it, improving efficiency losses in the interface. The part numbers given in the following applications are recommended, but other types may be more appropriate depending on voltage and power levels.

When troubleshooting external power transistor circuits, ensure that clean, sharp-edged waveforms are driving the interface and power transistors. Monitor these waveforms with an oscilloscope—disconnect the inductor, and tie the V_{FB} input (pin 8) high through a 10K resistor. This will cause the regulator to pulse at maximum duty cycle without drawing excessive inductor currents. Check for expected on time and off time, and look for slow rise times that might cause the power transistor to enter its linear operating region.

The following external power transistor circuits may demand some adjustment to resistor values to satisfy various power levels and input/output voltages. C_X and L_X values must be selected according to the design equations (pages 2-213 and 2-214).

Inverting Medium Power Application

Figure 8 is a schematic of an inverting medium power supply (250mW to 1W) using an external PNP switch transistor. Supply voltage is applied to the IC via R3: when the internal switch transistor is turned on current through R4 is also drawn through R3; creating a voltage drop from base to emitter of the external switch transistor. This drop turns on the external transistor.

Voltage pulses on the supply lead (pin 6) do not affect circuit operation because the internal reference and bias circuitry have good supply rejection capabilities. A power Schottky diode is used for higher efficiency.

Inverting High Power Application

For higher power applications (500mW to 5W), refer to Figure 9. This circuit uses an extra external transistor to provide well controlled drive current in the correct phase to the power switch transistor. The value of R3 sets the drive current to the switch by making the interface transistor act as a current source. R4 and R5 must be selected such that the RC time constant of R4 and the base capacitance of Q2 do not slow the response time (and affect duty cycle), but not so low in value that excess power is consumed and efficiency suffers. The resistor values chosen should be proportional to the supply voltage (values shown are for +5V).

Step-Down Power Applications

Figures 16 and 17 show medium and high power interfaces modified to perform step-down functioning. The design

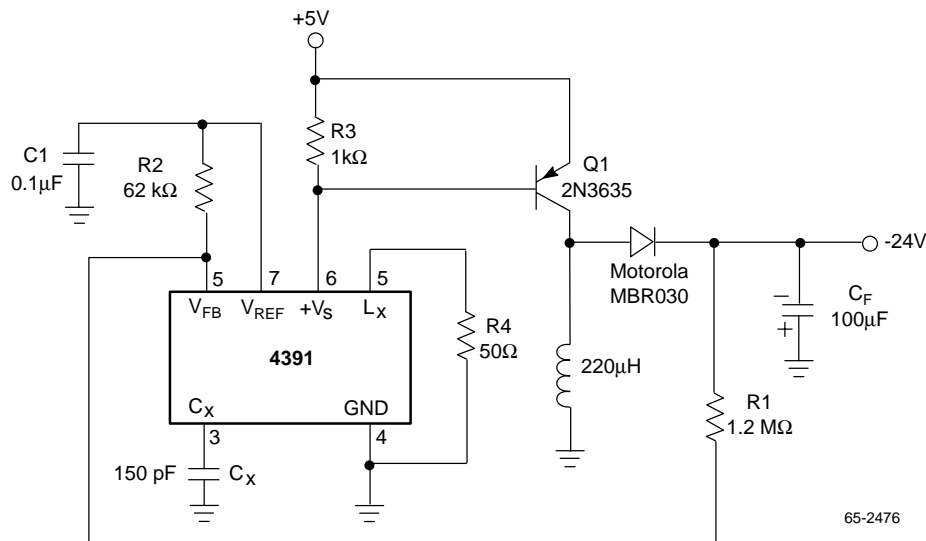

65-2476

Figure 14. Inverting Medium Power Application

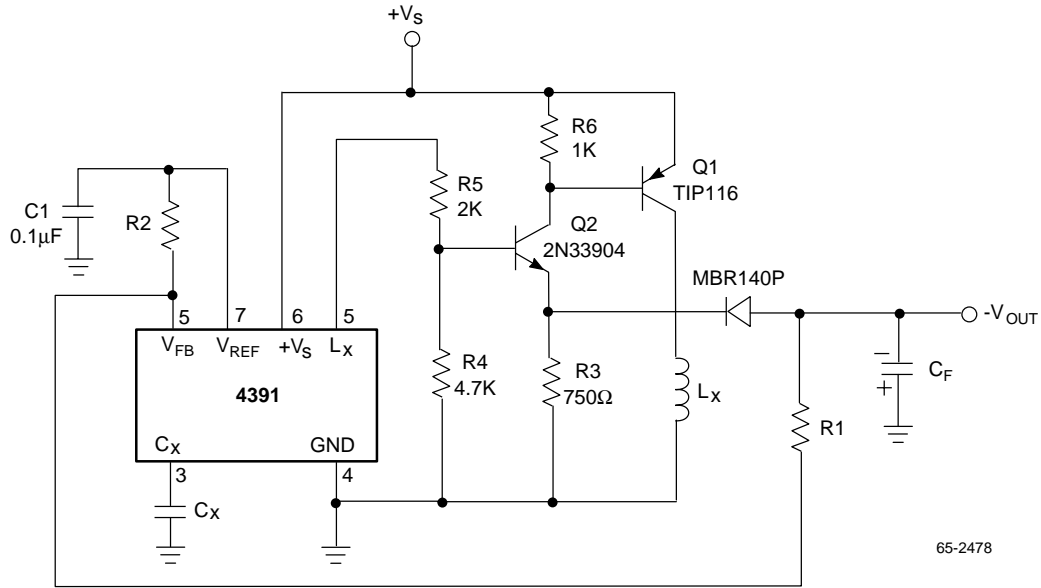

Figure 9. Inverting High Power Application

equations and suggestions for the circuits of Figures 14 and 15 also apply to these circuits. For a certain range of load power, the RC4193 can be used for step-down applications. A load range from 400mW to 2W can be sustained with fewer components (especially when stepping down greater than 30V) than the comparable RC4391 circuit. Refer to Raytheon's RC4191/4192/4193 data sheet for a schematic of this medium power step-down application.

Voltage Dependent Oscillator

The RC4391's ability to supply load current at low battery voltages depends on the inductor value and the oscillator frequency. Low values of inductance or a low oscillator frequency will cause a higher peak inductor current and therefore increase the load current capability. A large inductor current is not necessarily best, however, because the large amount of energy delivered with each cycle will cause a large voltage ripple at the output, especially at high input voltages. This trade-off between load current capability and output ripple can be improved with the circuit connection shown in Figure 18. This circuit uses the low battery detector to sense for a low battery voltage condition and will decrease the oscillator frequency after a pre-programmed threshold is reached.

The threshold is programmed exactly as the normal low battery detector connection:

$$V_{TH} = V_{REF} \left(\frac{R4}{R5} + 1 \right)$$

When the battery voltage reaches this threshold the comparator will turn on the open collector transistor at pin 2, effectively pulling C_Y in parallel with C_X. This added capacitance will reduce the oscillator frequency, according to the following equation:

$$F_O(\text{Hz}) = \frac{4.1 \times 10^{-6}}{C_X(\text{pF}) + C_Y(\text{pF})}$$

Current Limiting

The oscillator (C_X) pin can be used to add short circuit protection and to protect against over current at start-up (when using large values for the output filter capacitor—greater than 100 μF). A transistor V_{BE} is used as a current sensing comparator which resets the oscillator upon sensing an over current condition, thus providing cycle-by-cycle current limiting. Figure 19 shows how this is applied.

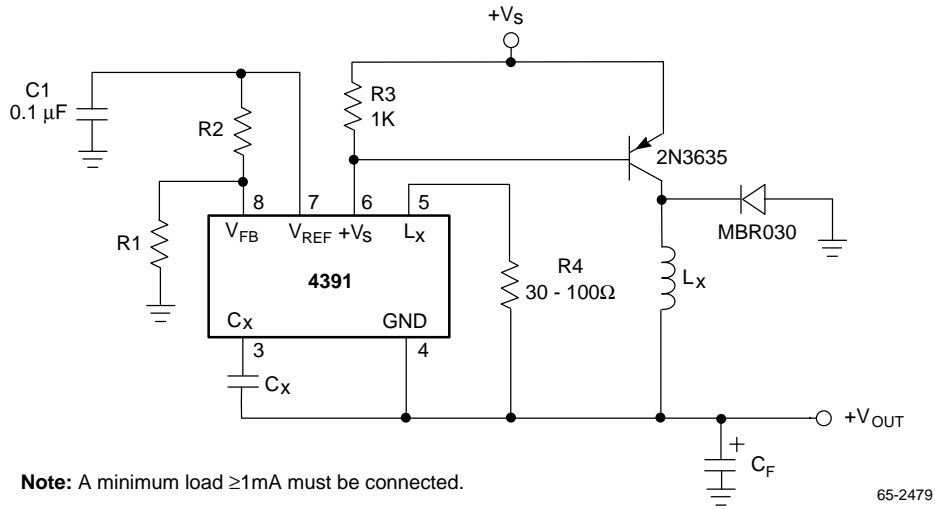

Figure 16. Step-Down Medium Power Application

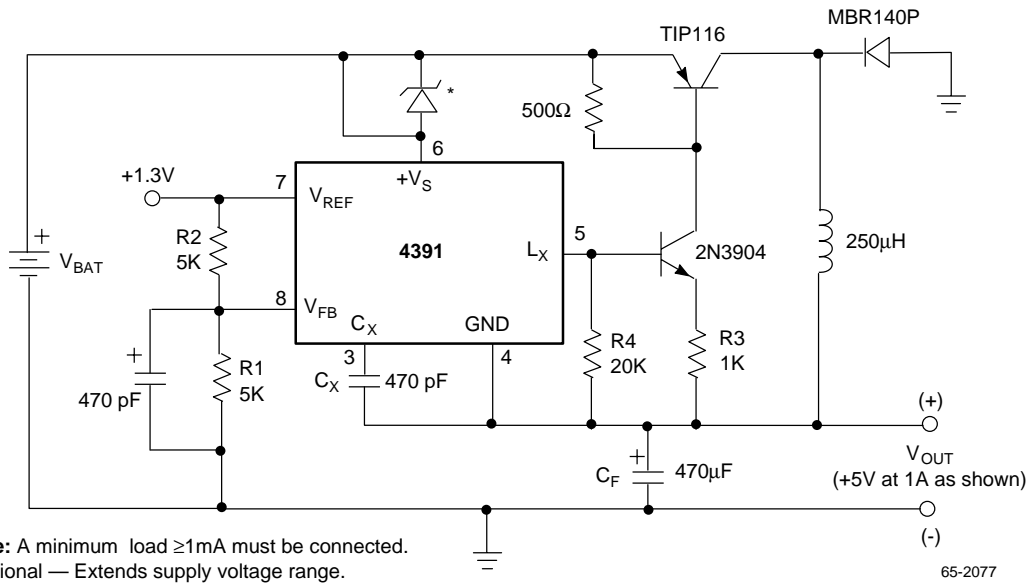

Figure 17. Step-Down High Power Application

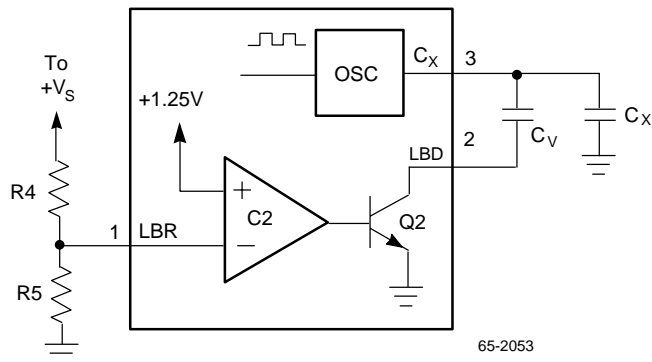

Figure 18. Voltage Dependent Oscillator

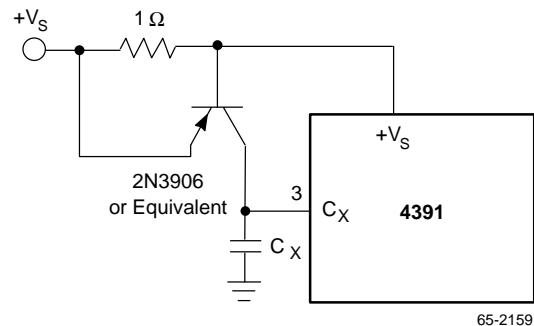
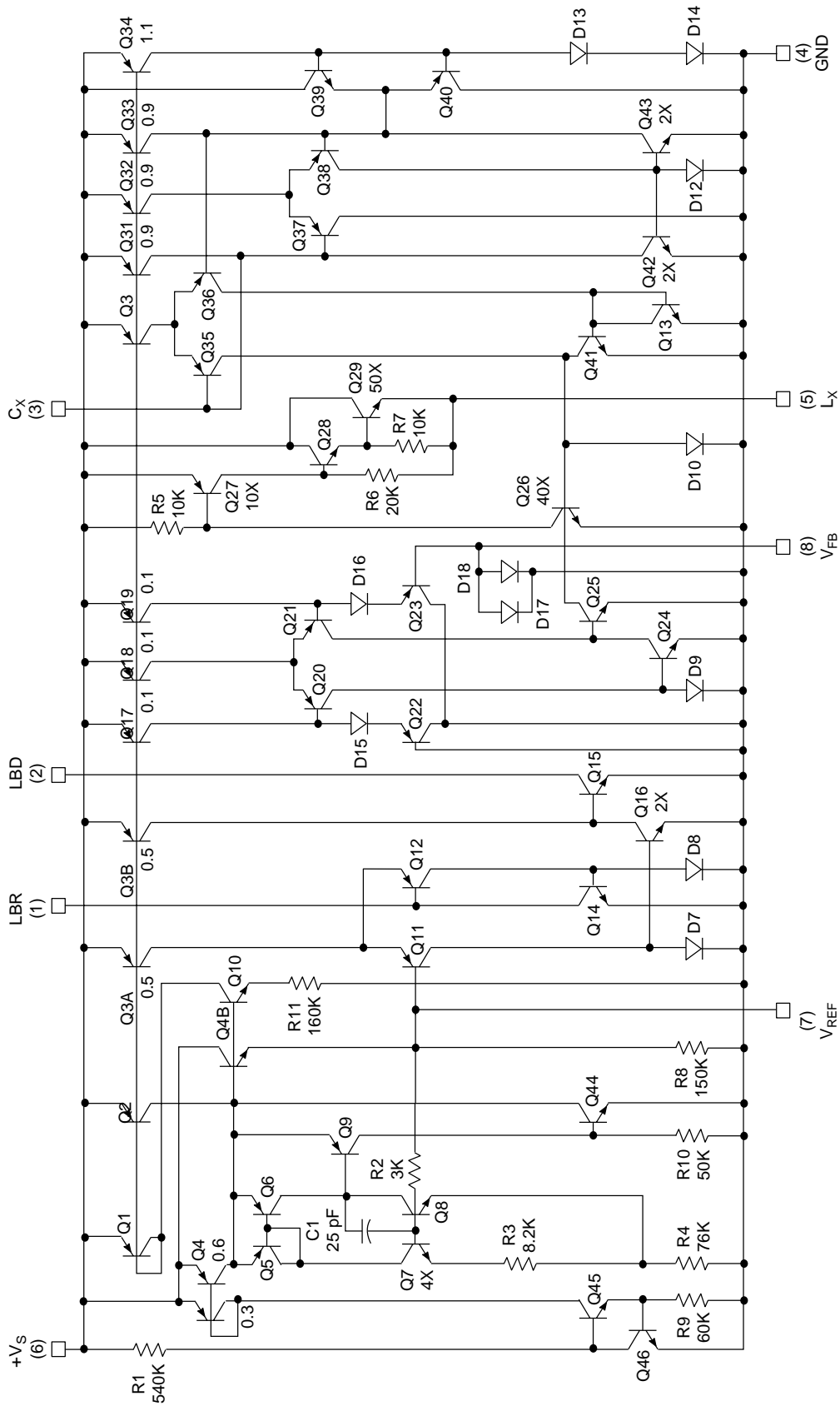

Figure 18. Current Limiting

Simplified Schematic Diagram



65-6364

Troubleshooting Chart

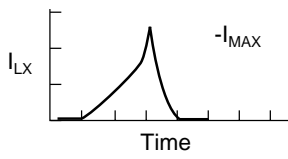
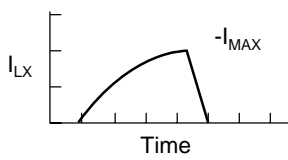
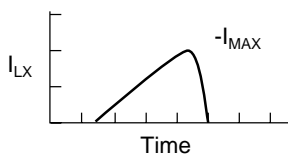
Symptom	Possible Problems
Draws excessive supply current on star-up.	Inductance value too low. Output frequency (FO) too low. Combination of low resistance inductor and high value filter capacitor — needs current limiting circuit (Figure 13).
Output voltage is low.	Inductance value too high for FO or core saturating.
Inductor "sings" with audible hum.	Not potted well or bolted loosely.
LX pin appears noisy — scope will not synchronize.	Normal operating condition.
 <p>Inductor current shows nonlinear waveform.</p>	Inductor is saturating: <ol style="list-style-type: none"> 1. Core too small. 2. Core too hot. 3. Operating frequency too low.
 <p>Inductor current shows nonlinear waveform.</p>	Waveform has resistive component: <ol style="list-style-type: none"> 1. Wire size too small. 2. Power transistor lacks base drive. 3. Components not rated high enough. 4. Battery has high series resistance.
 <p>Inductor current is linear until high current is reached.</p>	External transistor lacks base drive or beta is too low.
Poor efficiency.	Core saturating. Diode or transistor: <ol style="list-style-type: none"> 1. Not fast enough. 2. Not rated for current level (high VCESAT). High series resistance. Operating frequency too high.
Motorboating (erratic current pulses).	Loop stability problem — needs feedback from VOUT to VFB (pin 8), 100pF to 1000pF

Pot Core Inductor Design

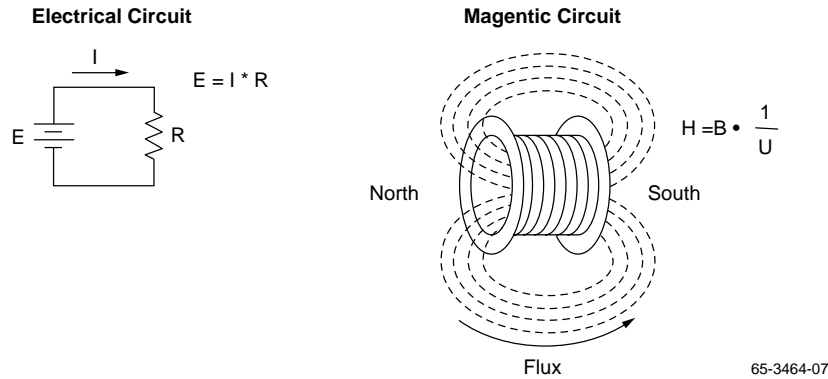

Figure 20. Electricity vs. Magnetism

Electricity Versus Magnetism

Electrically the inductor must meet just one requirement, but that requirement can be hard to satisfy. The inductor must exhibit the correct value of inductance (L, in Henrys) as the inductor current rises to its highest operating value (I_{MAX}). This requirement can be met most simply by choosing a very large core and winding it until it reaches the correct inductance value, but that brute force technique wastes size, weight and money. A more efficient design technique must be used.

Question: What happens if too small a core is used?

First, one must understand how the inductor's magnetic field works. The magnetic circuit in the inductor is very similar to a simple resistive electrical circuit. There is a magnetizing force (H, in oersteds), a flow of magnetism, or flux density (B, in Gauss), and a resistance to the flux, called permeability (U, in Gauss per oersted). H is equivalent to voltage in the electrical model, flux density is like current flow, and permeability is like resistance (except for two important differences discussed to the right).

First Difference: Permeability instead of being analogous to resistance, is actually more like conductance (1/R). As permeability increases, flux increases.

Second Difference: Resistance is a linear function. As voltage increases, current increases proportionally, and the resistance value stays the same. In a magnetic circuit the value of permeability varies as the applied magnetic force varies. This nonlinear characteristic is usually shown in graph form in ferrite core manufacturer's data sheet.

As the applied magnetizing force increases, at some point the permeability will start decreasing, and therefore the amount of magnetic flux will not increase any further, even as the magnetizing force increases. The physical reality is that, at

the point where the permeability decreases, the magnetic field has realigned all of the magnetic domains in the core material. Once all of the domains have been aligned the core will then carry no more flux than just air, it becomes as if there were no core at all. This phenomenon is called saturation. Because the inductance value, L, is dependent on the amount of flux, core saturation will cause the value of L to decrease dramatically, in turn causing excessive and possibly destructive inductor current.

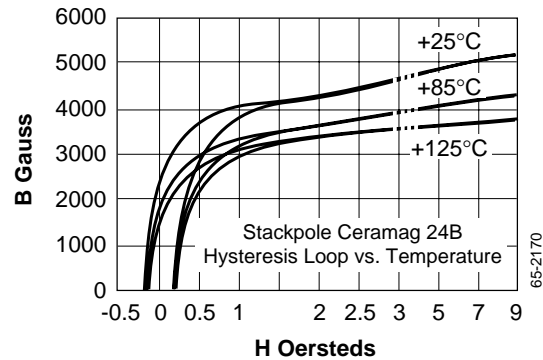

Figure 21. Typical Manufacturer's Curve Showing Saturation Effects

Pot Cores for RC4391

Pot core inductors are best suited for the RC4391 switching regulator for several reasons:

1. **They are available in a wide range of sizes.** RC4391 applications are usually low power with relatively low peak currents (less than 500mA). A small inexpensive pot core can be chosen to meet the circuit requirements.
2. **Pot cores are easily mounted.** They can be bolted directly to the PC card adjacent to the regulator IC.

- Pot cores can be easily air-gapped.** The length of the gap is simply adjusted using different washer thicknesses. cores are also available with predetermined air gaps.
- Electromagnetic interference (EMI) is kept to a minimum.** the completely enclosed design of a pot core reduces stray electromagnetic radiation—an important consideration if the regulator circuit is built on a PC card with other circuitry.

Not quite. Core size is dependent on the amount of energy stored, not on load power. Raising the operating frequency allows smaller cores and windings. Reduction of the size of the magnetics is the main reason switching regulator design tends toward higher operating frequency. Designs with the RC4391 should use 75 kHz as a maximum running frequency, because the turn off delay of the power transistor and stray capacitive coupling begin to interfere. Most applications are in the 10 to 50 kHz range, for efficiency and EMI reasons.

The peak inductor current (I_{MAX}) must reach a high enough value to meet the load current and simultaneously the inductor value is decreased, then the core can be made smaller. For a given core size and winding, an increase in air gap spacing (an air gap is a break in the material in the magnetic path, like a section broken off a doughnut) will cause the inductance to decrease and I_{MAX} (the usable peak current before saturation) to increase.

The curves shown are typical of the ferrite manufacturer's power HF material, such as Siemens N27 or Stackpole 24B, which are usually offered in standard millimeter sizes including the sizes shown.

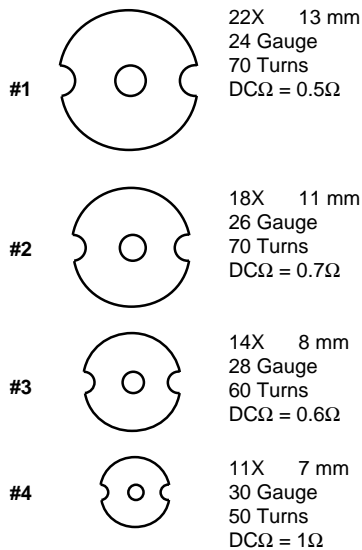

Use of the Design Aid Graph

- From the application requirement, determine the inductor value (L) and the required peak current (I_{MAX}).
- Observe the curves of the design aid graph and determine the smallest core that meets both the L and I requirements.
- Note the approximate air gap at I_{MAX} for the selected core, and order the core with the gap. (If the gapping is done by the user, remember that a washer spacer results in an air gap of twice the washer thickness, because two gaps will be created, one at the center post and one at the rim, like taking two bites from a doughnut.)
- If the required inductance is equal to the indicated value on the graph, then wind the core with the number of turns shown in the table of sizes. The turns given are the maximum number for that gauge of wire that can be easily wound in cores winding area.
- If the required inductance is less than the value indicated on the graph, a simple calculation must be done to find the adjusted number of turns. Find A_L (inductance index) for a specific air gap.

$$\frac{L(\text{indicated})}{\text{Turns}^2} = A_L \left(\frac{\text{inHenries}}{\text{Turn}^2} \right)$$

Then divide the required inductance value by A_L to give the actual turns squared, and take the square root to find the actual turns needed.

$$\text{ActualTurns} = \frac{L(\text{required})}{A_L}$$

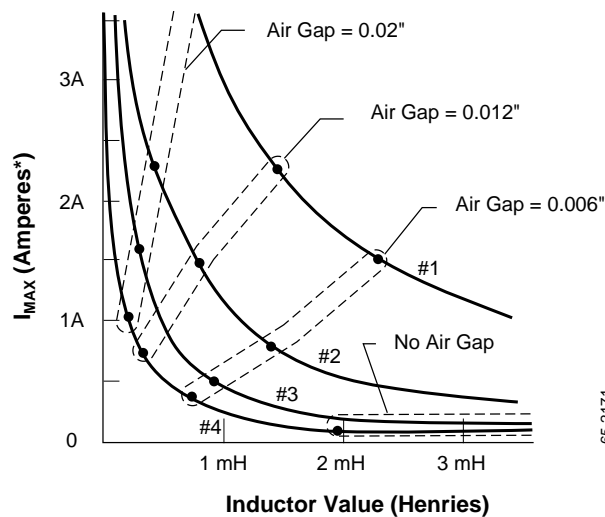

*Includes safety margin (25%) to ensure nonsaturation

Figure 22. Inductor Design Aid

If the actual number of turns is significantly less than the number from the table then the wire size can be increased to use up the leftover winding area and reduce resistive losses.

6. Wind and gap the core as per calculations, and measure the value with an inductance meter. Some adjustment of the number of turns may be necessary.

The saturation characteristics may be checked with the inductor wired into the switching regulator application circuit. To do so, build and power up the circuit. Then clamp an oscilloscope current probe (recommend Tektronix P6042 or equivalent) around the inductor lead and monitor the current in the inductor. Draw the maximum load current from the application circuit so that the regulator is running at close to full duty cycle. Compare the waveform you see to those pictured.

Check for saturation at the highest expected ambient temperature.

7. After the operation in circuit has been checked, reassemble and pot the core using a potting compound recommended by the manufacturer.

If the core material differs greatly in magnetic characteristics from the standard power material shown in Figure 16, then the following general equation can be used to help in winding and gapping. This equation can be used for any core geometry, such as an E-E core.

$$L_x = \frac{(1.26)(N^2)(A_e)(10^8)}{g = (l_e/\mu_e)}$$

Where:

- N = number of turns
- A_e = core area from data sheet (in cm²)
- l_e = magnetic path length from data sheet (in cm)
- μ_e = permeability of core from manufacturer's graph
- g = center post air gap (in cm)

Manufacturers

Below is a list of several pot core manufacturers:

Ferroxcube Company
5083 Kings Highway
Saugerties, NY 12477

Indiana General Electronics
Keasley, NJ 08832

Siemens Company
186 Wood Avenue South
Iselin, NJ 08830

Stackpole Company
201 Stackpole Street
St. Mary, PA 15857

TDK Electronics
13-1, 1-Chrome
Nihonbaski, Chuo-ku, Tokyo

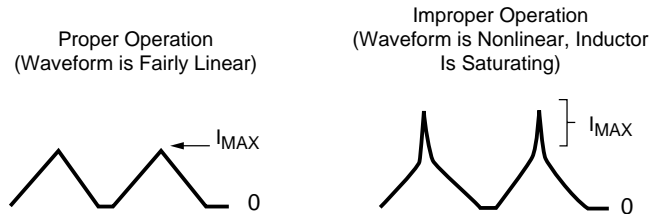

65-3464-08

Figure 23. Inductor Current Waveforms

Mechanical Dimensions

8-Lead Ceramic DIP Package

Symbol	Inches		Millimeters		Notes
	Min.	Max.	Min.	Max.	
A	—	.200	—	5.08	
b1	.014	.023	.36	.58	8
b2	.045	.065	1.14	1.65	2, 8
c1	.008	.015	.20	.38	8
D	—	.405	—	10.29	4
E	.220	.310	5.59	7.87	4
e	.100 BSC		2.54 BSC		5, 9
eA	.300 BSC		7.62 BSC		7
L	.125	.200	3.18	5.08	
Q	.015	.060	.38	1.52	3
s1	.005	—	.13	—	6
α	90°	105°	90°	105°	

Notes:

1. Index area: a notch or a pin one identification mark shall be located adjacent to pin one. The manufacturer's identification shall not be used as pin one identification mark.
2. The minimum limit for dimension "b2" may be .023 (.58mm) for leads number 1, 4, 5 and 8 only.
3. Dimension "Q" shall be measured from the seating plane to the base plane.
4. This dimension allows for off-center lid, meniscus and glass overrun.
5. The basic pin spacing is .100 (2.54mm) between centerlines. Each pin centerline shall be located within ± 0.010 (.25mm) of its exact longitudinal position relative to pins 1 and 8.
6. Applies to all four corners (leads number 1, 4, 5, and 8).
7. "eA" shall be measured at the center of the lead bends or at the centerline of the leads when " α " is 90°.
8. All leads – Increase maximum limit by .003 (.08mm) measured at the center of the flat, when lead finish applied.
9. Six spaces.

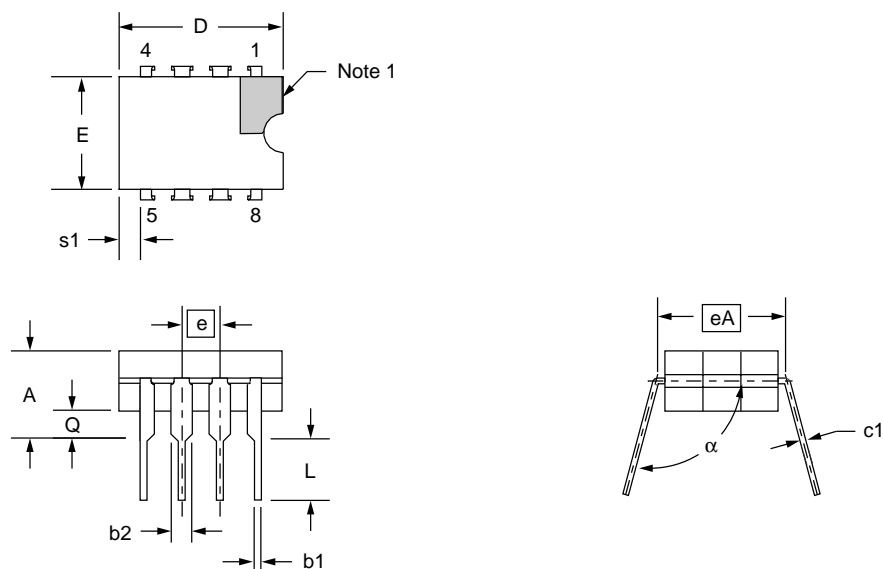

Mechanical Dimensions (continued)

8-Lead Plastic DIP Package

Symbol	Inches		Millimeters		Notes
	Min.	Max.	Min.	Max.	
A	—	.210	—	5.33	
A1	.015	—	.38	—	
A2	.115	.195	2.93	4.95	
B	.014	.022	.36	.56	
B1	.045	.070	1.14	1.78	
C	.008	.015	.20	.38	4
D	.348	.430	8.84	10.92	2
D1	.005	—	.13	—	
E	.300	.325	7.62	8.26	
E1	.240	.280	6.10	7.11	2
e	.100 BSC		2.54 BSC		
eB	—	.430	—	10.92	
L	.115	.160	2.92	4.06	
N	8°		8°		5

Notes:

1. Dimensioning and tolerancing per ANSI Y14.5M-1982.
2. "D" and "E1" do not include mold flashing. Mold flash or protrusions shall not exceed .010 inch (0.25mm).
3. Terminal numbers are for reference only.
4. "C" dimension does not include solder finish thickness.
5. Symbol "N" is the maximum number of terminals.

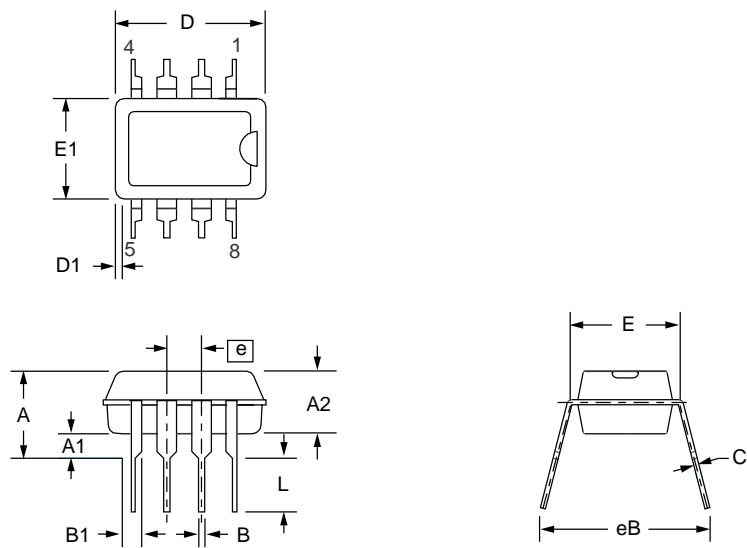

Mechanical Dimensions (continued)

8-Lead SOIC Package

Symbol	Inches		Millimeters		Notes
	Min.	Max.	Min.	Max.	
A	.053	.069	1.35	1.75	
A1	.004	.010	0.10	0.25	
B	.013	.020	0.33	0.51	
C	.008	.010	0.20	0.25	5
D	.189	.197	4.80	5.00	2
E	.150	.158	3.81	4.01	2
e	.050 BSC		1.27 BSC		
H	.228	.244	5.79	6.20	
h	.010	.020	0.25	0.50	
L	.016	.050	0.40	1.27	3
N	8		8		6
α	0°	8°	0°	8°	
ccc	—	.004	—	0.10	

Notes:

1. Dimensioning and tolerancing per ANSI Y14.5M-1982.
2. "D" and "E" do not include mold flash. Mold flash or protrusions shall not exceed .010 inch (0.25mm).
3. "L" is the length of terminal for soldering to a substrate.
4. Terminal numbers are shown for reference only.
5. "C" dimension does not include solder finish thickness.
6. Symbol "N" is the maximum number of terminals.

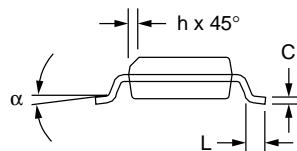
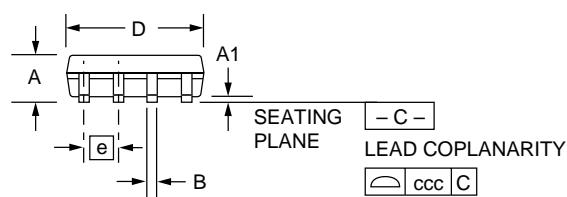
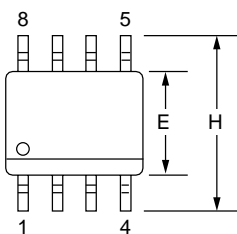

Ordering Information

Part Number	Package	Operating Temperature Range
RC4391N	8 Lead Plastic DIP	0°C to +70°C
RC4391M	8 Lead Plastic SOIC	0°C to +70°C
RV4391N	8 Lead Plastic DIP	-25° C to +85°C
RM4391D	8 Lead Ceramic DIP	-55°C to +125°C

The information contained in this data sheet has been carefully compiled; however, it shall not by implication or otherwise become part of the terms and conditions of any subsequent sale. Raytheon's liability shall be determined solely by its standard terms and conditions of sale. No representation as to application or use or that the circuits are either licensed or free from patent infringement is intended or implied. Raytheon reserves the right to change the circuitry and any other data at any time without notice and assumes no liability for errors.

LIFE SUPPORT POLICY:

Raytheon's products are not designed for use in life support applications, wherein a failure or malfunction of the component can reasonably be expected to result in personal injury. The user of Raytheon components in life support applications assumes all risk of such use and indemnifies Raytheon Company against all damages.

Raytheon Electronics
Semiconductor Division
350 Ellis Street
Mountain View CA 94043
415 968 9211
FAX 415 966 7742